

MOUNTING BRACKETS

FOR Dome Camera Series

Direct Ceiling Installation
WV-Q105



DIMENSIONS

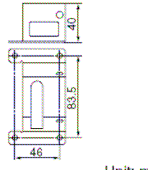

Unit: mm

Embedded Ceiling Installation
WV-Q106

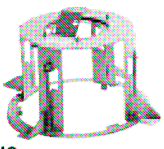

DIMENSIONS

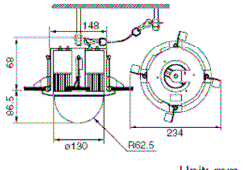

Unit: mm

Embedded Ceiling Installation
WV-Q116



DIMENSIONS

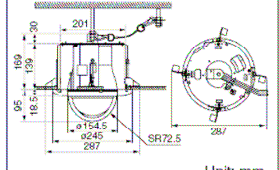

Unit: mm

Suspended Ceiling Installation
WV-Q107A



DIMENSIONS

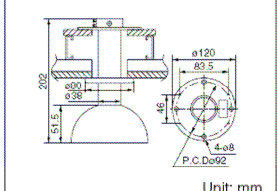

Unit: mm

Suspended Ceiling Installation
WV-Q117



DIMENSIONS

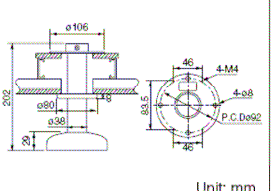

Unit: mm

Wall Installation
WV-Q108A

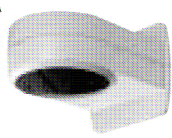

DIMENSIONS

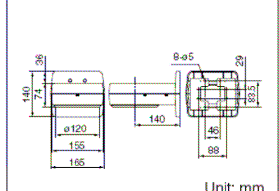

Unit: mm

Wall Installation
WV-Q118

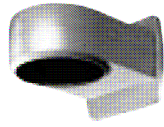

DIMENSIONS

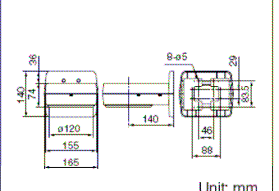

Unit: mm

Model No.	WV-Q105	WV-Q106	WV-Q116	WV-Q107A	WV-Q117	WV-Q108A	WV-Q118
WV-CS950	○	—	○	—	○	—	○
WV-CS570	○	○	—	—	○	—	○
WV-NS320	○	○	—	○	—	○	—

○: Possible

FOR WV-CW960 Series

Wall Mount Bracket
WV-Q122



DIMENSIONS

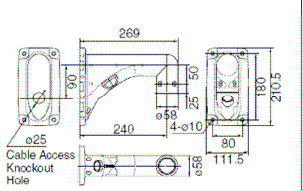

Unit: mm

MOUNTING BRACKETS

Ceiling Mount Bracket
WV-7010A



DIMENSIONS

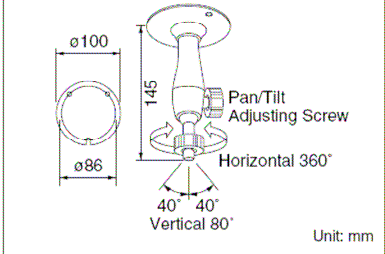

Unit: mm

Wall Mount Bracket
WV-7015



DIMENSIONS

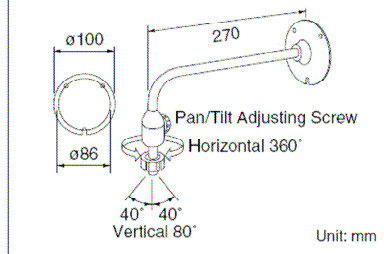

Unit: mm

Wall and Ceiling Mount Bracket
WV-831



DIMENSIONS

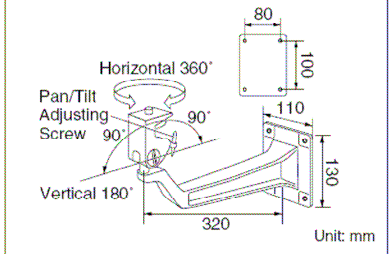

Unit: mm

Mounting Brackets	WV-7010A	WV-7015	WV-831
Housing	WV-7110A	WV-7110A	WV-7110A
Pan/Tilt Mechanism	No	No	No
Mounting	Ceiling or stand	Wall	Wall or Ceiling
Mounting Head	Multi-directional	Multi-directional	Multi-directional
Load Weight	4 kg	4 kg	9 kg
Weight	0.28 kg	0.63 kg	1 kg

Safety Wire Kit
WV-Q141
(for WV-7010A)

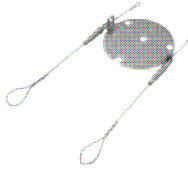

Status of Installation

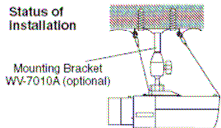

Mounting Bracket WV-7010A (optional)

DIMENSIONS

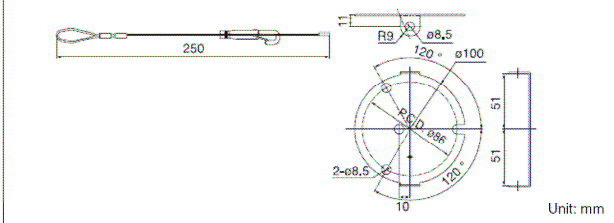

Unit: mm

Safety Wire Kit
WV-Q140
(for WV-831)

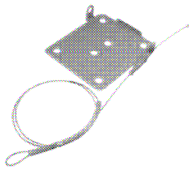

Status of Installation-1

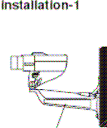

Wall Mount Bracket WV-831 (optional)

Status of Installation-2

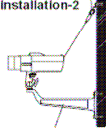

Wall Mount Bracket WV-831 (optional)

DIMENSIONS

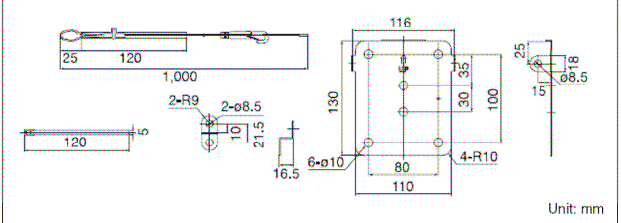

Unit: mm